



Kerala State Drugs and Pharmaceuticals Ltd
(A Govt. of Kerala Enterprise)
KALAVOOR, ALAPPUZHA

Phone :0477-2258184 (Extn:207) ; Email :purchase@ksdp.in
Web :http://www.ksdp.co.in

KSDP/PS/F-ST/2026-27/400265/T-126

12-5-2026

Notice Re- Inviting Sealed Tender for the supply of 10 ML Vials - 150000 Nos

Quotations are invited for the supply of undermentioned goods/ services as per the attached specifications on FOR destination basis at our factory site at Kalavoor,Alappuzha, Kerala state

SI No.	ITEM CODE & DESCRIPTION	UNIT	QUANTITY	EMD	TENDER FEES
1	41100003 10ml Vials	NOS	1,50,000 NOS	Rs. 4665	Rs.1120

Quotations should be submitted as per the Proforma given below on your letter head.

SI No.	Name of item	Make	Rate per unit (including freight, if any)	GST %	Offer validity	Remarks, if any
--------	--------------	------	---	-------	----------------	-----------------

Due Date/Time : 20-May-26 / 1.00PM

Opening Date/Time : 21-May-26 / 1.00PM

Separate demand drafts should be submitted for Tender fee & EMD in favour of Kerala State Drugs & Pharmaceuticals Ltd payable at Alappuzha, Kerala.

MSME/Udyam Registration companies will be exemption from EMD & Tender fee

Offer validity*: Minimum 7 days offer validity from the date of closure of bid submission. Quotation received with offer validity less than 7 days from the date of closure of bid submission will be entirely rejected.

Please Submit Your Lowest Offer in a Sealed Cover Superscribing "SEALED TENDER FOR THE SUPPLY OF 10 ML Vials- 150000 Nos. DUE ON 20.05.2026 TENDER ID:KSDP/PS/F-ST/2025-26/400265/T-126 (ST-54)"on or before 20.05.2026, 01.00 PM to the Office of the Managing Director, Kerala State Drugs & Pharmaceuticals Ltd, Kalavoor - P.O, Alappuzha - 688522 in two cover system.

1st cover: should comprise of technical bid. Must submit COA, EMD&TC (Provide proof for exemptions of EMD & TC, if any) & other relevant documents for technical evaluation.

2nd cover: should comprise of price bid.

Quotation received in any other mode or not as per the prescribed format will be rejected.

TERMS & CONDITIONS

- 1.Payment terms :- 30 days after the receipt of the material along with documents, subject to QC approval.
- 2.Mode of payment:- E-Payment.
- 3.Delivery Period:- Supply should be effected within 15 days on award of PO
- 4.Special instructions:- Bidder's Stamp Should be on COA

HOD - Purchase



KERALA STATE DRUGS AND PHARMACEUTICALS LTD,
KALAVOOR PO, ALAPPUZHA, KERALA-688522

Packaging Material Specification

Name of the Material: **10ML VIAL**

SOP No:	KSDP/SOP/SPEC02	Spec. No:	VIAL-10ML
Effective date:	01/01/2019	Revision No:	01

10 ml flat bottomed vials made of USP type I Flint GLASS of uniform surface finish without having bubbles and blow holes or apparent strains.

Height	: (49-51mm)
Over flow volume	: (13.50-15 ml)
Outer body diameter	: (24.50-25.50mm)
Mouth/ID	: (12.50-12.90mm)
Neck ID	: (16.60-17.40mm)
Height from base to constriction	: (34.75mm)
Body wall thickness	: (1.7-2.1 mm)
Mouth O.D	: (19.70-20.10mm)
Weight	: (18-19.5g)

The vial should comply with all chemical tests specified in the Indian pharmacopoeia. The supplier should submit samples physically and it should pass the performance test.

Drawing attached

Prepared by	Checked By	Reviewed By	Reviewed By	Approved By	Authorized By
Jr. Manager QA	QC Head	Asst Manager, Production	Dy. Manager, Production	Production Head	QA Head
<i>Sini</i> 01/01/19	<i>Spk</i> 01/01/19	<i>Asst Mgr</i> 05/01/19	<i>Dy Mgr</i> 05/01/19	<i>Prod Head</i> 05/01/19	<i>QA Head</i> 05/01/19

UNCONTROLLED COPY

MASTER COPY



KERALA STATE DRUGS AND PHARMACEUTICALS LTD,
KALAVOOR PO, ALAPPUZHA, KERALA-688522

Name of the Material: 10ML VIAL

SOP No:	KSDP/SOP/SPEC02	Spec. No:	VIAL-10ML
Effective date:	01/01/2019	Revision No:	01

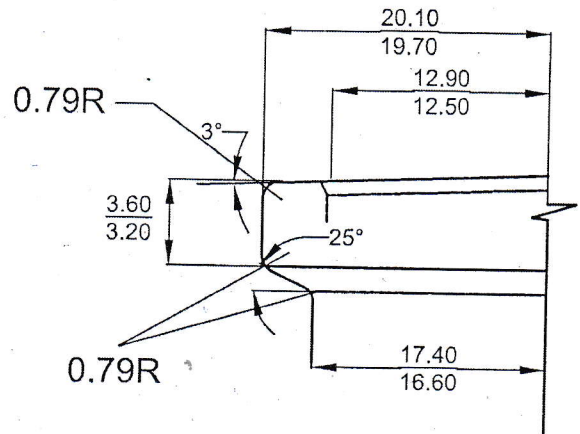
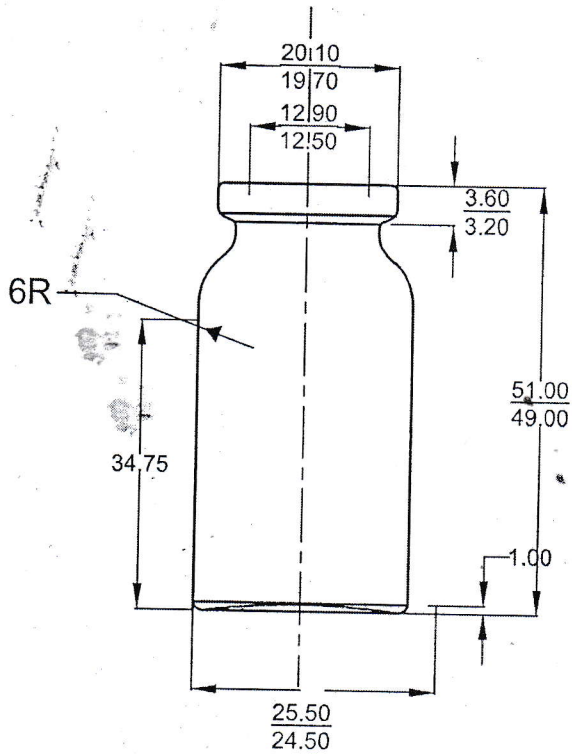

NECK FINISH DETAIL
SCALE ~ 4:1

Prepared by	Checked By	Reviewed By	Reviewed By	Approved By	Authorized By
Jr. Manager QA	QC Head	Asst Manager, Production	Dy. Manager, Production	Production Head	QA Head
<i>Srin</i> 01/01/19	<i>Qm</i> 01/01/19	<i>Asst</i> 05/01/19	<i>Dy</i> 5/1/19	<i>PH</i> 5/1/19	<i>QA</i> 05/01/19

CONTROLLED COPY

MASTER COPY